



MANUFACTURER'S INSTALLATION INSTRUCTIONS

CAREFULLY READ ALL THE INSTALLATION INSTRUCTIONS BEFORE PROCEEDING WITH YOUR CENTURION STONE VENEER PROJECT

Centurion recommends you check with the local building code authorities in your area. Check for special requirements that might apply to your area. Codes vary from area to area. Centurion Stone's 30 Year Limited Warranty applies only when installation is in accordance with the manufacturer's instructions.

CALCULATING REQUIRED FOOTAGE

Determine the stone required by measuring the area to be covered.

STEP 1 Measure and multiply the length of the wall by the height of each wall to be covered. This will give you the gross area square footage of flats.

STEP 2 Measure and calculate the total square footage of all openings (windows, doors, etc.). Deduct this footage from the gross footage amount. This is your net square feet requirement for flats.

STEP 3 If outside corners are required, measure the total linear feet of corners needed. When figuring corners to flats, a good rule to remember is a linear foot of corners averages approximately 3/4 of a foot of flat coverage. Subtract this footage from your flat footage, and this gives you the net feet of flats.

PLACING YOUR STONE ORDER

- Order your net square feet of flats.
- Order your net linear feet of corners.
- Order any accessories needed by the piece. (Hearthstone, Keystones, Window Trim, etc.)

You may wish to order extra stone and component pieces to allow for trimming and cutting. Extra stone may be required for special laying patterns outside the recommended 3/4" mortar joint that most patterns are designed with. Example: Tighter or zero mortar joints.

TOOL REQUIREMENTS

Choose the right tools for your job.

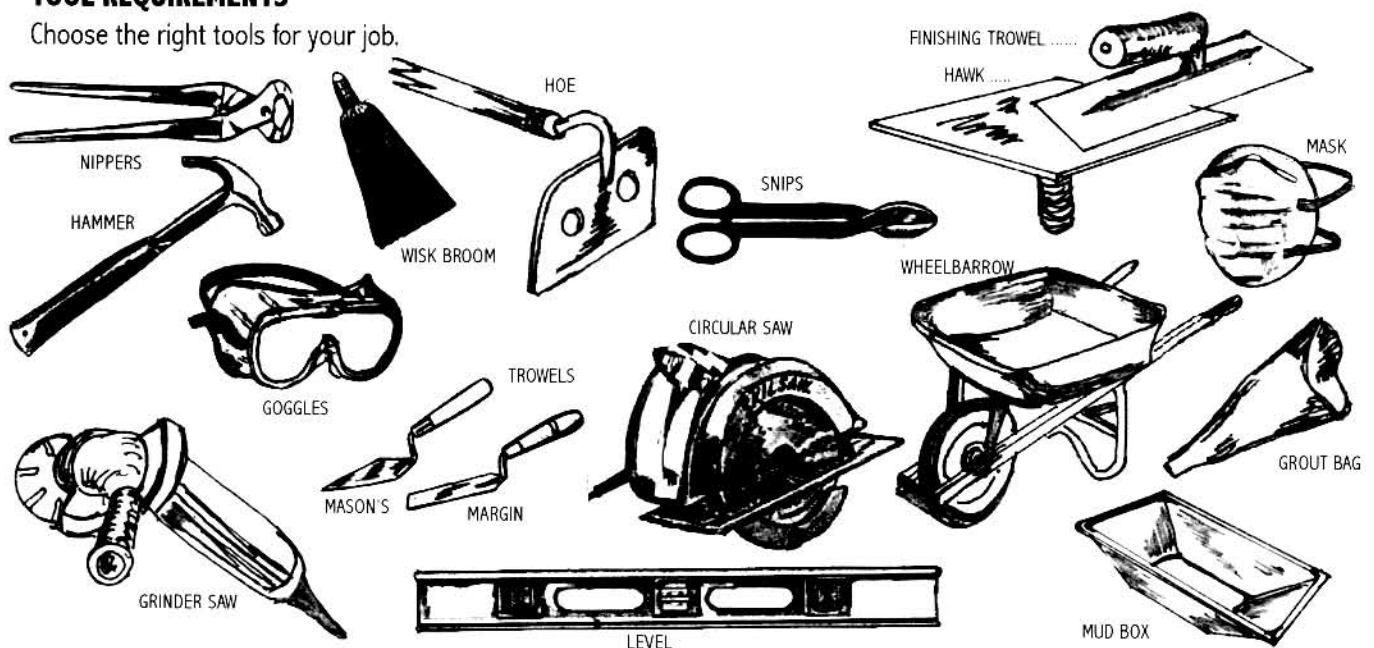

SUNDRY MATERIAL REQUIREMENTS

MORTAR COMPONENTS

- (A) Type Masonry to be used
- (B) Mortar Color: Iron oxide color (if desired)
- (C) Masonry sand

FASTENERS

- (A) Use galvanized fasteners (nail, staples, concrete nail, etc.)
- (B) Over metal surfaces use pancake head type screws.
Example: Type S-12 Pancake Head Super Tite Screws by United States Gypsum Company.

METAL LATH

- (A) Minimum 2.5 lbs. expanded metal lath galvanized Diamond mesh type. Rust inhibitive black metal lath may be used on the interior walls.
- (B) Jobs over open studs or metal building require a minimum of 3.4 lbs 3/8" rib galvanized lath.
- (C) Other mesh or laths accepted by your local building codes.

SURFACE PREPARATION

OVER OPEN STUDS

Apply paper-backed galvanized 3.4 lbs. 3/8" rib expanded metal lath to the studs using galvanized nails every 6" vertically on stud centers with a minimum 1" penetration. Overlap lath sides no less than 1/2" and ends no less than 1". For metal studs use corrosion-resistant self-tapping screws with a 3/8" head that provides a minimum 3/8" penetration beyond the inside metal surface.

OVER WOOD PRODUCTS (plywood, drywall, paneling, etc.)

Cover the wall surface with a weather resistant barrier. Lap joints by applying felt horizontally with the upper layer lapped over the lower layer not less than 2" and end laps not less than 6". Barrier to be equal to U.S.C. standard number 14-1. Install 2.5 lbs diamond mesh expanded metal lath. Use galvanized lath for exterior and black metal lath (non-galvanized) may be used for interior. Lap lath sides not less than 1/2" and end laps not less than 1". (It is important to attach lath with the small diamonds pointing upwards.) On inside and outside corners turn the corner 16" minimum each way. (This is an important step.) (Figure 1) Barrier to be equal to ASTM C-847.

After attaching lath, apply an adequate mortar scratch coat over the lath and allow it to set before applying stone veneer. Attach wire lath using galvanized nails on 6" centers vertically and 16" centers horizontally penetrating studs a minimum of 1".

OVER RIGID INSULATION BOARD

Surface preparation is the same as over rigid wood related sheathing with the following exceptions: Nails should be 4" on centers vertically and 16" centers horizontally, penetrating studs a minimum of 1".

METAL BUILDING OR PANELS

Surface preparation is the same as over rigid wood sheathing, except the lath should be attached with self-tapping screws with a minimum 3/8" head that provides 3/8" minimum penetration beyond the inside metal surface. Screws should be like under fasteners sections.

CLEAN & UNTREATED MASONRY

No surface preparation is needed. **Note:** On newly poured concrete examine the area for release agents (form oils). If present, etch surface with muriatic acid and rinse thoroughly. You may need to score surface with a wire brush to ensure a good bond.

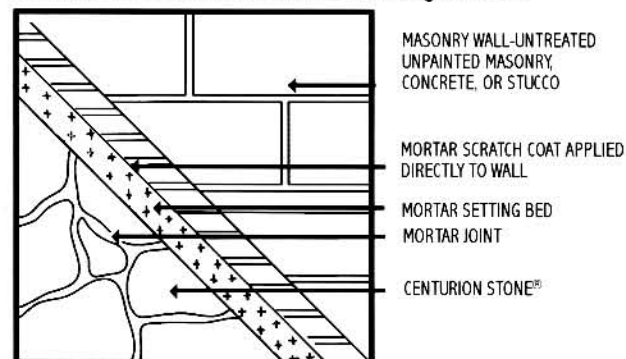

PAINTED, SEALED OR DIRTY MASONRY

You must clean the surface back to the original masonry surface by sandblasting, water blasting, acid etching or wire brushing before installing stone veneer. If you are unable to use the above methods you may elect to attach metal lath without a vapor barrier.

Attach lath with corrosion-resistant concrete nails or other approved fasteners.

Note: If sandblasting is used wash wall area to eliminate any dust before applying stone.

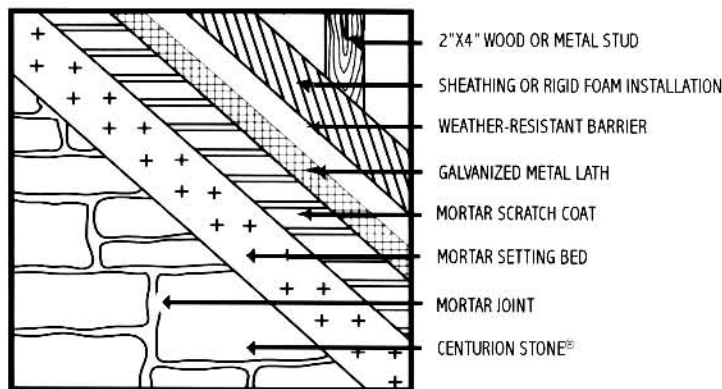
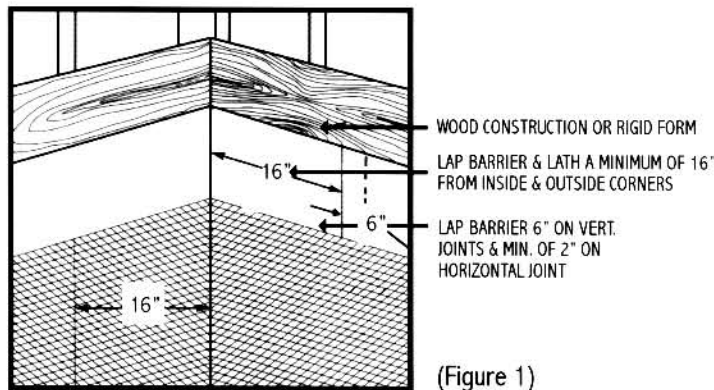
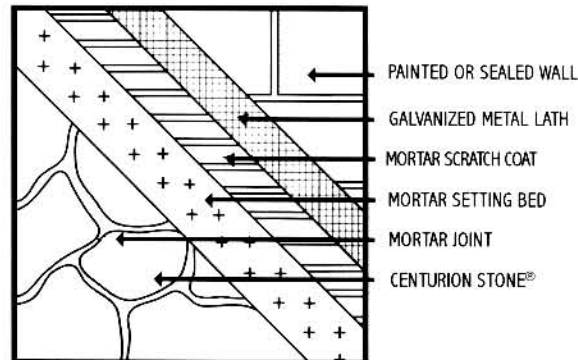

BUILDING CODES

Code requirements vary from area to area. Check codes in your area on special requirements that may affect your installation.

PREPARE WORK AREA

It is recommended to lay out a reasonable amount of stone pieces so you can see how the pattern looks assembled. Determine the desired pattern by mixing stones from several boxes. Plan for variety and contrast in your overall design by using small pieces next to large pieces, thick next to thin, textured next to smooth. Mix colors from several boxes to ensure a good blend of color shades.

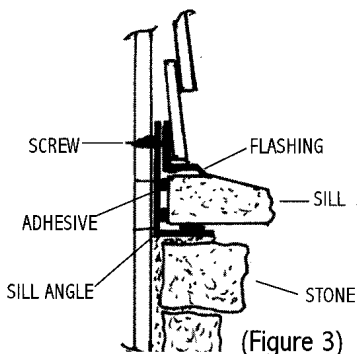

(Figure 3)

WINDOW SILL INSTALLATION

Window sills are available in several styles from Centurion Stone. Choose the style that best accents your job. Install sills per drawing to eliminate moisture from entering structure. (Figure 2)

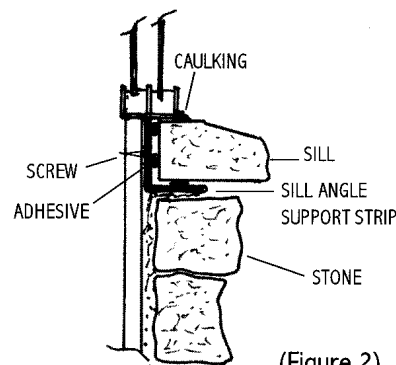

(Figure 2)

WAINSCOT/WATERTABLE INSTALLATION

Watertable pieces are available from Centurion Stone. The pieces allow you to trim and seal the stone wall in a wainscot installation or to seal the top of a stone area that meets another siding product. Install sills per drawing to help eliminate any moisture from entering wall. (Figure 3)

PREPARING MORTAR

Mix mortar to a firm, moist consistency. If mortar is too wet it will be messy to work with and weak in strength. If too dry mortar will not provide a proper bond. Mix all ingredients thoroughly to obtain the best workability and desirable properties of masonry mortar. Centurion Products, Inc. does not recommend lowering the freezing point of the mortar by using anti-freeze compounds.

MIXING BY MECHANICAL MIXER

Machine mixing time should be 3 to 5 minutes after all materials are together. For the best results mix 3/4 of the water, 1/2 of the sand with the cementitious materials. Mix briefly and add the remaining parts. Top mix off by adding remaining water needed to obtain the proper slump of mortar. Mortar should have an "oatmeal-like" consistency.

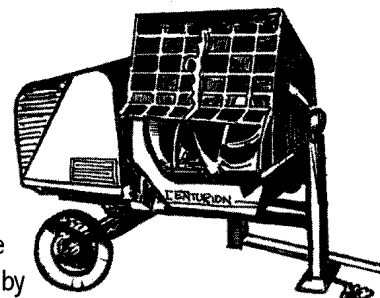

MIXING BY HAND

Dry mix all materials together in a wheelbarrow or mud box by raking material from end to end of mixing container. Add 3/4 of required water and mix thoroughly for batch uniformity. Add remaining water as necessary to obtain the proper slump of mortar. Re-tempering of mortar by adding additional water is acceptable, but no mortar should be used beyond a two and a half hour period after mixing.

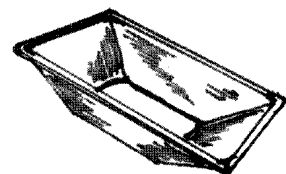
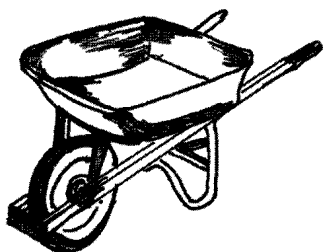

Note: On the jointless or drystack series do not use the grouted joint mixes to set the stone with. You may use them for the scratch coating. A concrete bonding agent should be used to ensure additional bonding and adhesion. Check with your local dealer for a recommended brand in your area. When installing a jointless or drystack series, color can be added to the mortar to compliment the base color of the stone. Tinting of mortar will greatly enhance the finished appearance.

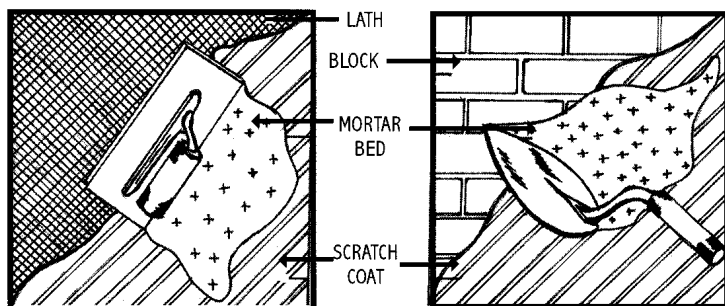

APPLYING MORTAR TO THE WALL AREA SCRATCH COAT

After all wire lath is in place and all flashings, electrical boxes and etc. are installed, you may apply the base scratch coat. Use a plaster or masons trowel to apply mortar thick to the surface sealing around all windows, doors, electric boxes and etc. Scratch the surface area to ensure a good bond when applying the setting coat.

MORTAR MIX DESIGNS

GRouted JOINT INSTALLATION

PARTS BY VOLUME	PORTLAND CEMENT OR BLENDED	MASONRY CEMENT TYPE (N)	HYDRATE LIME OR LIME PUTTY	SAND
MORTAR TYPE	2	—	1	5 TO 7
S	3	—	—	5 TO 7
N	—	1	1 1/2 to 1 1/4	2 1/4 to 3
N	—	1	—	2 1/4 to 3

MIX FOR DRY-STACK SERIES

PARTS BY VOLUME	PORTLAND CEMENT OR BLENDED		SAND
MORTAR TYPE	3	*2 PARTS THINSET MORTAR	7
—	2	BONDING AGENT 1 TO 1 (with water)	7
S	3	BONDING AGENT 1 TO 1 (with water)	7

* MUST BE LATEX MODIFIED THINSET FOR EXTERIOR USE MEETING ANSI A118.4

SETTING COAT

Select mortar type to be used from mortar chart. Mix per instructions and apply to wall in areas not to exceed 10 square feet or in areas that will not setup before stone is applied. Application method is the same as scratch coat.

WEATHER CONDITIONS

In hot weather conditions it may become necessary to moisten the wall before applying the setting coat. Weather conditions may also require moistening the back of each stone. This is best done using a fine spray of water, or a wet brush. This step is important to prevent excessive absorption of moisture from the mortar. Application must be protected from freezing temperatures by sheltering the wall as mortar will not set up properly under such conditions. Do not use anti-freeze compounds to lower the freezing point of mortar.

APPLYING CENTURION STONE

STARTING POINT

You may start your installation from the top down or bottom up. Working from top down may help to avoid splashing or dripping mortar on previously applied stones. Care must be taken to avoid smearing the mortar. If this occurs it should be removed after mortar has dried to a crumbly state with a whisk broom.

GROUT JOINTS

Joints will vary in width depending on pattern being installed or customers preference. Install stone with uniform size grout joints. Avoid long straight lines. When installing patterns that are coursed or laid in a horizontal style, special attention should be given in keeping the pattern level and plumb. It is of particular importance to stagger the joint lines both vertically and horizontally. (Figure 4)

Ensure adequate coverage

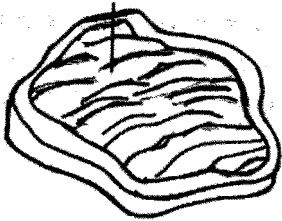

SETTING THE STONES

Completely cover the entire back surface of each stone. Press each stone into the mortar setting bed firmly enough to squeeze mortar out around the stone's edges. Apply pressure to the stone and wiggle the stone left and right to ensure a good bond. Using a margin trowel, strike off the excess mortar around the stones edges before placing the next piece. If stones back has dust, dirt or loose particles, brush off prior to applying mortar to stones back then proceed with application.

INSTALL CORNERS FIRST

If installation requires corner pieces apply these first. Notice that the corners have a long and short leg. Alternate these in opposite directions as you apply them. (Figure 5)

WINDOWS AND DOOR OPENINGS

If job requires accessories (keystone, sills, etc.) install these first around the openings leaving a joint area between the stone and frame. Fill joint area with caulking or masonry and tool so water will shed away from the joint area. (Figure 6)

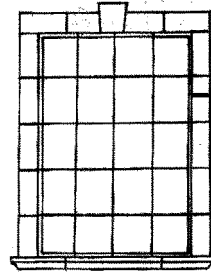

(Figure 6)

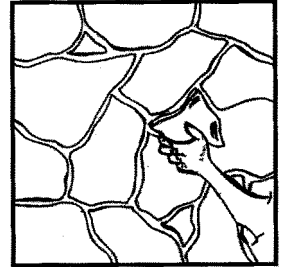

(Figure 4)

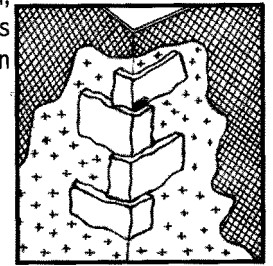

(Figure 5)

CAULK
THIS
JOINT AREA

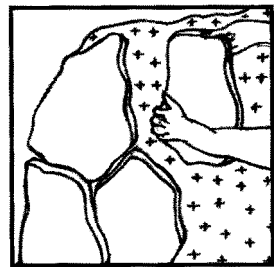

INSTALLING FLATS

After corner pieces and window and door trim pieces are in place, install flats working toward center of the wall. Cut and trim pieces as required to maintain joint consistency. Select and mix stones from different boxes throughout the installation to give a balance to shapes, sizes, colors, thickness and textures.

TRIMMING STONES

When trimming or cutting stones to obtain the best fit you may use a hatchet, widemouth nippers, or a masons trowel edge. Straight cuts are best done using a small grinder or circular saw with a diamond or masonry saw blade. Cutting should be done out-

side as dust will occur. Safety glasses and dust mask should always be worn when cutting a masonry product. Cut edges are installed so they are not visible (down when below eye level and up above eye level). To conceal cut or broken pieces cover the edges when grouting. Some broken stones may be found in the boxes.

These also may be used in filling gaps between larger stones.



GROUTING OF JOINTS

After stone is in place grouting may be necessary depending on stone pattern. Grouting is done with a grout bag. Fill a bag half full with mortar and insert into joint area. Squeeze bag while moving bag down joint line until area is filled. Avoid smearing mortar on surface of stone. If accidental smears occur allow mortar to dry and brush off with a whisk broom. Never use a wet brush or wire brush to remove a mortar stain.

DRY STACK

It may be necessary to do touch up grouting on dry stack patterns such as void areas between stone pieces, around windows, doors, and openings to conceal cut or broken edges.

FINISHING JOINTS

When the mortar joints become firm (normally 30-60 min.) or thumb print dry they should be pointed up with a wooden or metal jointing tool. Rake out excessive mortar to obtain desired depth. While raking mortar joints, compact and seal edges around each piece of stone. To obtain a professional looking finish maintain proper and even joints. Brush away all smears and mortar spots within a few hours of finishing. Never allow mortar to set up over night, as it will cause staining that will be almost impossible to remove.

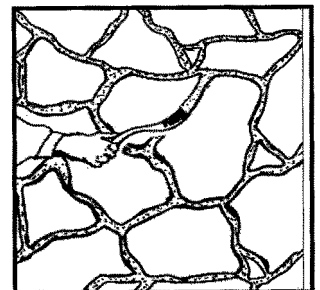
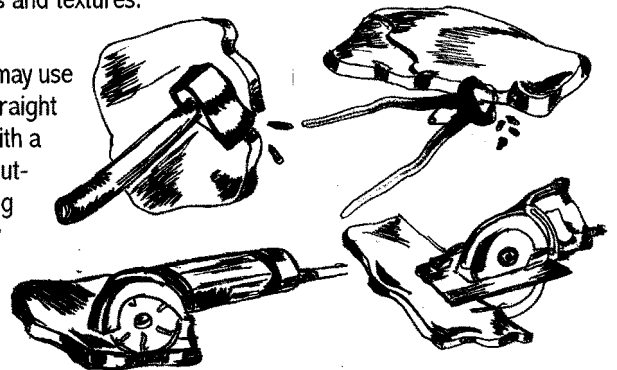

INSTALLING HEARTH STONES

Hearthstones are not recommended or warranted for exterior use or as a surface subject to foot traffic. Hearths at floor level or raised hearths are normal use for hearth pieces. We recommend when used in these installations the mortar joint area be filled to the top of each hearth piece.

RAISED HEARTHES

Do not cantilever a hearth piece out more than the stone below, usually 1 1/2". Grout under the hearth piece to fill the void between the hearth pieces and the flats. This will give direct support to the hearth piece.

MORTAR BED FOR HEARTH PIECES

Place strips of mortar approximately 3/4" thick and 3" wide where hearth pieces are to be placed. Place hearth pieces on mortar bed and tap down to level and align. Place additional pieces and level to each other. If trimming is required, use same method as called for in the flats.

SEALING HEARTH PIECES AND FLATS

Sealing of Centurion Stone or hearth pieces is not necessary but sealing will assist in cleaning of smoke and soot stains should they occur around fireplace opening. Sealing stone at grade lines to prevent mud stains is an option some masons prefer. Some sealers may deepen the stones color. It is recommended the sealer be tested on several loose pieces of stone to make sure the end result is acceptable. Only a good quality masonry sealer should be used of the penetrating breathable type.

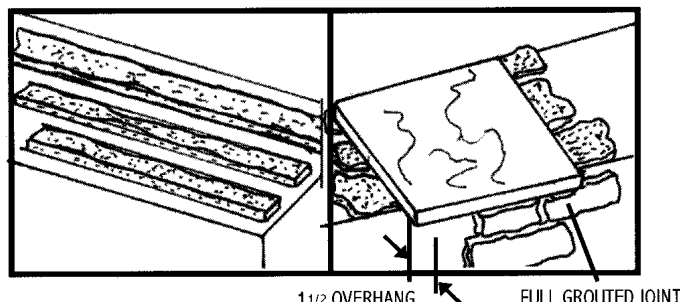

1 1/2 OVERHANG

FULL GROUTED JOINT

GENERAL HELPFUL INFORMATION

CLEANING

Cleaning may never be necessary. But if needed use a solution of granulated soap or detergent and water with a bristle brush. Rinse immediately with fresh water.

DO NOT ATTEMPT THE FOLLOWING!

Cleaning with a wire brush • High pressure power washing • Using acid or acid containing products.
These methods will give you undesirable results!

SALTS AND DE-ICING AGENTS

Since all masonry and concrete products are vulnerable to damage incurred by salts or other chemicals used to remove snow and ice. Centurion Stone is NOT warranted against damage from these products. DO NOT use these products on areas immediately adjacent to a Centurion Stone application.

POOLS AND FOUNTAINS

Centurion Stone is not recommended to be installed below the water line in swimming pools or water fountains where chlorine or other water chemicals are used. Discoloring may occur from these chemicals.

SCUFFING

Scuffing occurs when pieces of product rub against one another. Scuffing occurs in all natural stone and occasionally in Centurion Stone. Usually this enhances the appearance of the stone wall. If scuff marks need to be removed clean stone as mentioned in the Cleaning Section of this brochure and most marks will disappear.

EFFLORESCENCE

Efflorescence is a water-soluble salt that penetrates masonry walls or products. As the water evaporates a deposit is left on the masonry surface (usually white in color). It can occur on any masonry type surface (brick, stucco, concrete, natural stone, etc.). It may even occur on Centurion Stone on rare occasions. To remove efflorescence you must allow the stone to dry thoroughly, then scrub vigorously with a stiff brush with clean water, and rinse thoroughly. For a more difficult problem, scrub with a solution of 1 part household vinegar to 5 parts water then rinse thoroughly.

CAPPING OFF EXTERIOR WALLS

When stone is applied to exterior walls, or retaining walls or other surfaces where a cap is needed it is recommended that Centurion Capstones be used, or a poured-in-place concrete cap to provide adequate runoff protection. Centurion caps should extend 2" on each side of wall area. Centurion Stone corners are not recommended for capping walls. All retaining walls should be damp proofed at the fill side with weep holes and proper drainage prior to the stone being applied.

CHIMNEY CAPS

All chimney chases must be capped with a one piece cap that extends 1" beyond the finished stones surface to eliminate water from entering the chase.

GOOD BUILDING PRACTICES

CODES

Good building practices are essential in stone work. Building codes vary from area to area and it's recommended you know and follow your local codes. Know your local codes prior to starting your installation. For additional information, refer to our National Evaluation Report No. NER-543.

EXTERIOR APPLICATIONS

On exterior applications the incorrect installation or absence of flashing, gutters, or downspouts may result in diversion of water runoff onto finished surfaces. Masonry and other building products may stain under these conditions and combined with severe freeze-thaw conditions may eventually cause surface damage. The application of Centurion Stone under these conditions is not recommended.

COLD WEATHER AND FOUL WEATHER CONDITIONS

Prior to your mortar setting up, protect your finished work from possible rainstorms or the threat of freezing during installation and curing. Use a plastic cover weighted down to protect wall areas. Mortar will not setup properly under these conditions.

CONTACT YOUR LOCAL CENTURION STONE DEALER FOR OTHER INFORMATION THAT MAY BE NEEDED ON A PARTICULAR JOB INSTALLATION.



NES



BOCA



ICBO



SBCCI



ICC EVALUATION SERVICE, INC.
Evaluate • Inform • Protect



SET THE BUILDING UP RIGHT AND SAVE

CENTURION® STONE

BRICK OR NATURAL STONE

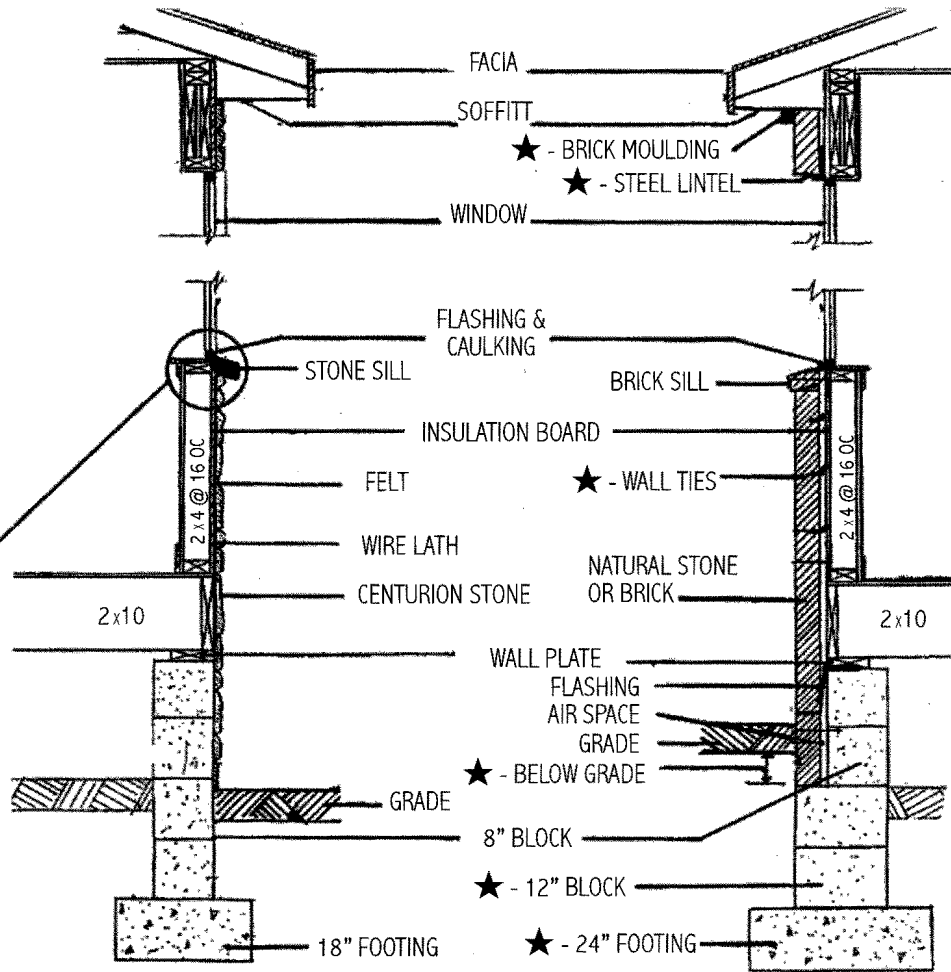

★ - SAVINGS

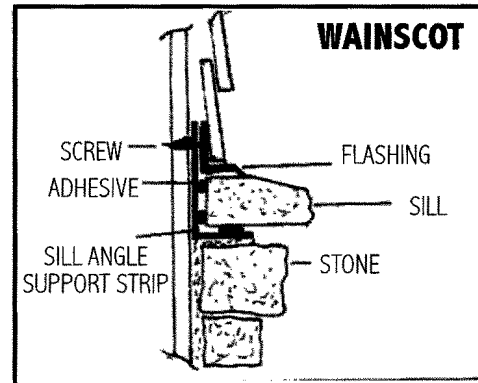
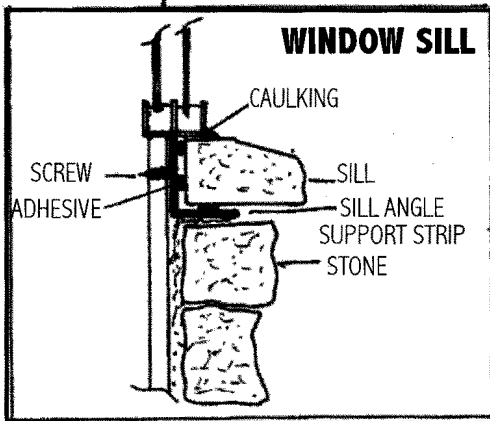

FACTORY LOCATION CENTURION STONE PRODUCTS, INC.

50 Van Buren Street
Nashville, TN 37208

www.centurionstone.com

Phone: 615-256-6694
Fax 615-726-1795